

VIVAX

Heat Pumps catalogue



High efficiency

Long-term profitability

Flexible operation

More comfort

Content

Product overview	3
How heat pump works	4
Split and monoblock system	5
Flexible operation and more comfort	6
Complete solution for heating, cooling and domestic hot water Split system	7
Complete solution for heating, cooling and domestic hot water Monoblock system	8
DC Inverter technology Innovative design	9
Pool heat pumps	10
SPECIFICATIONS	
Split systems	12
Pool heat pumps	15
Monoblock systems	16



Heat pumps

Complete solution for heating, cooling and domestic hot water

Heat pumps are becoming increasingly available economic and ecological solutions enabling heating, cooling and domestic water. Their numerous benefits make them a top solution for all the living spaces.

WHY HEAT PUMPS?

Heat pumps use free energy from the environment. Energy sources can be earth, groundwater or air. Only cost of the heat pump operation is electric energy that the heat pump uses.

LONGTERM COST EFFECTIVENESS

Although the initial investment in a heat pump is a bit higher it is a long-term cost-effective investment, compared to traditional heating solutions based on fossil fuels. Savings in heating goes up to 75 %. Considering the high savings in energy consumption, average investment in heat pump completely returns in only a few years.

Efficiency coefficient (COP) of the VIVAX heat pumps is measured in different operation modes, considering the user needs. In heating mode coefficient is determined at 35 °C water outlet temperature where values are between 4.62 and 5.21 and at 55 °C temperature where values are between 3.31 and 3.52.

5 YEAR FACTORY WARRANTY

The warranty for VIVAX heat pumps is 60 months with mandatory annual service by an authorised service centre. This is a regular warranty for our heat pumps, and after the purchase, no additional registration of the device is required to obtain the warranty. Detailed information on warranty conditions and a list of authorised services can be found at vivax.com.



Product overview

Split system



Outdoor unit

Outdoor unit

Indoor unit

Capacity	4,0 kW	6,0 kW	8,0 kW	10,0 kW	12,0 kW	14,0 kW	16,0 kW	4,0 - 6,0 kW	8,0 - 10,0 kW	12,0 - 16,0 kW
220 ~ 240 - 1 Ph	•	•	•	•				•	•	•
380 ~ 415 - 3 Ph					•	•	•			

Split system



Pool systems



Capacity	4,0 - 6,0 kW	8,0 - 10,0 kW	12,0 - 16,0 kW	Capacity	7,0 kW	10,0 kW	12,0 kW
220 ~ 240 - 1 Ph	•	•	•	220 ~ 240 - 1 Ph	•	•	•
380 ~ 415 - 3 Ph				380 ~ 415 - 3 Ph			

Monoblock system

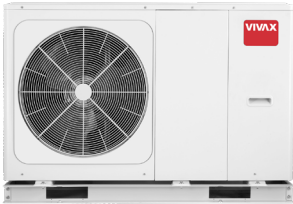

Capacity	4,0 kW	6,0 kW	8,0 kW	10,0 kW	12,0 kW	14,0 kW	16,0 kW	18,0 kW	22,0 kW	24,0 kW	30,0 kW
220 ~ 240 - 1 Ph	•	•	•	•				•			
380 ~ 415 - 3 Ph					•	•	•	•	•	•	•

How heat pump works

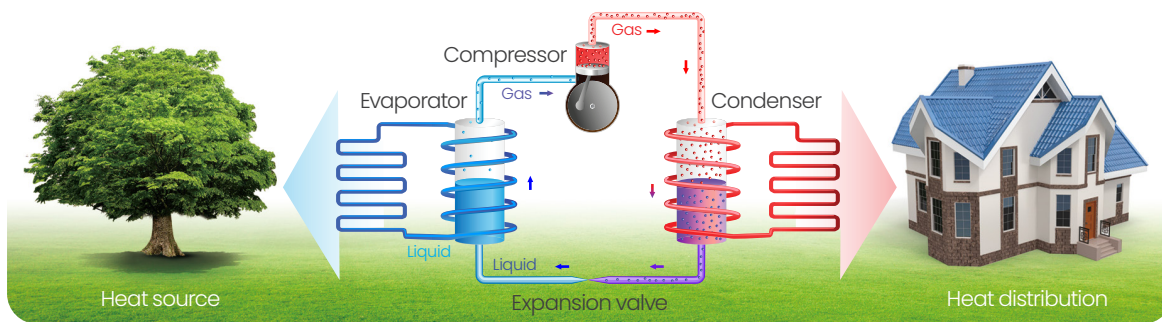

AIR TO WATER

VIVAX heat pumps are air to water type. Such a design does not require access to water in the soil or the occupation of large areas of land for installation. When choosing the optimal solution, it is important to take into account the operation range of the device with regard to the external temperature, which for VIVAX devices ranges from $-25\text{ }^{\circ}\text{C}$ to $+43\text{ }^{\circ}\text{C}$. VIVAX has monoblock and split units with capacities from 4.0 kW to 16.0 kW. All units use the ecological refrigerant R32. Devices with a capacity of 4.0 kW up to 10.0 kW have a single-phase power supply, and from 12.0 kW to 16.0 kW three-phase. In the split variant an internal unit, the hydrobox is connected to the external unit. In the hydrobox water for space heating and DHW is heated, or cooled if a space cooling is needed. In the monoblock version, the water is heated and cooled inside the outdoor unit.

CONTROL



- Touch screen
- LCD (Liquid Crystal Display)
- Error display
- Checking operating parameters
- Multi language
- Child lock function
- Built-in temperature sensor and Wi-Fi module
- Modbus protocol

Stage One

As the refrigerant passes through the expansion valve and expands, its temperature and pressure both drop.

Stage Two

With the temperature of the refrigerant being lower than the ambient temperature, heat passes from the air flowing over the air side heat exchanger to the refrigerant and the refrigerant evaporates.

Stage Three

When the refrigerant vapor passes through the compressor its pressure increases and its temperature rises above that of the water in hydronic system.

Stage Four

As the hot vapor refrigerant passes through the water side heat exchanger it heats the water in the hydronic system, which is then pumped indoors to the space heating terminals or hot water tank. The refrigerant cools and condenses and then ready to return to the expansion valve to start the cycle again.

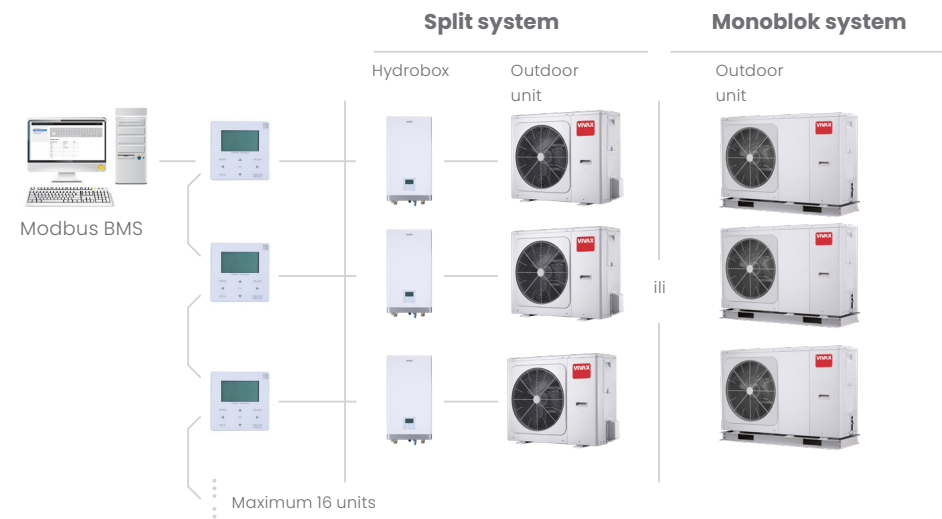

Split and monoblock system

Split system

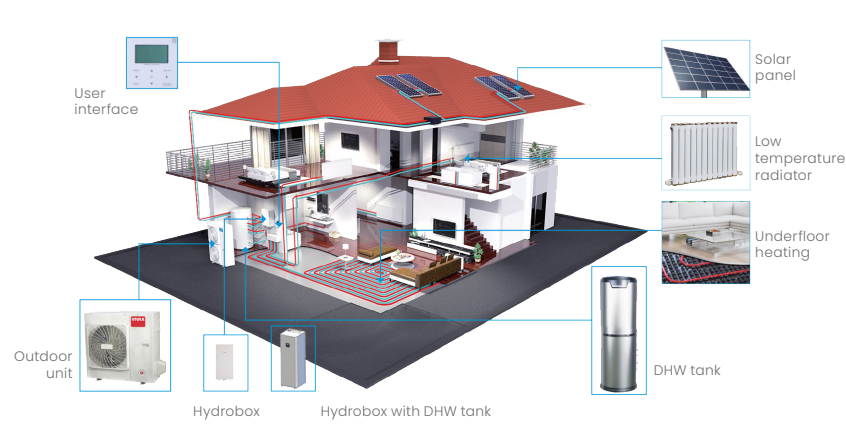

Application	Heating + Cooling + Domestic hot water
Type	Split (outdoor unit + hydrobox)
Refrigerant piping	Between the outdoor unit and hydrobox
Water piping	Between the hydrobox and indoor heating appliances
Installation	Under-floor heating loops Fan coil units Low temperature radiators Domestic hot water tank Auxiliary heat sources (such as water heaters and boilers)

SPLIT TYPE OUTDOOR UNIT

The outdoor unit absorbs heat from the outside air and transfers it inside through the refrigerant piping.

HYDROBOX

The hydrobox heats the water with refrigerant from the outdoor unit. The heated water circulates through heating apparatus such as floor heating, radiators, fan coil units as well as inner coil of domestic hot water tank.

DOMESTIC HOT WATER TANK

Hot water from the hydrobox is circulated through the domestic hot water tank heating water coil, heating the domestic hot water inside the tank. Immersion electric heaters could be installed in domestic hot water tanks as a backup.

USER INTERFACE

User interface is connected to the split unit through signal wire. Its main functions are ON / OFF, parameter setting, timer and service parameter setting.

Monoblock system

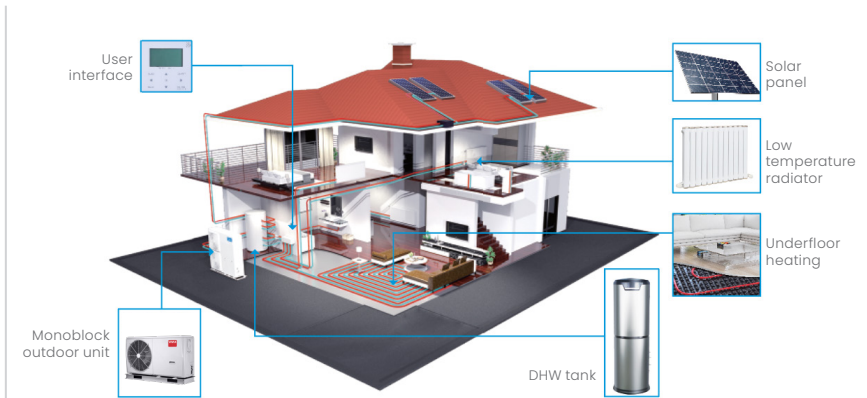

Application	Heating + Cooling + Domestic hot water
Type	Integrated (Heat pump and hydronic box are in the same casing)
Refrigerant piping	Inside outdoor unit
Water piping	Between outdoor unit and indoor heating appliances
Combinational parts (field supplied)	Under-floor heating coils Fan coil units Low temperature radiators Domestic hot water tank Auxiliary heat sources (such as water heaters and boilers)

MONOBLOCK OUTDOOR UNIT

Monoblock outdoor unit absorbs heat from the outside air and transfers it to the water in the hydronic modular, through water to supply heat to indoor side.

DOMESTIC HOT WATER TANK

Hot water from the monoblock unit is circulated through the domestic hot water tank's heating water coil, heating the domestic hot water inside the tank. Immersion heaters could be installed in domestic hot water tanks as a backup.

USER INTERFACE

User interface is connected to the monoblock unit through signal wire. Its main functions are ON/OFF, parameter setting, timer and service parameter setting.

Flexible operation and more comfort

Two zones controlled using user interface and thermostat.

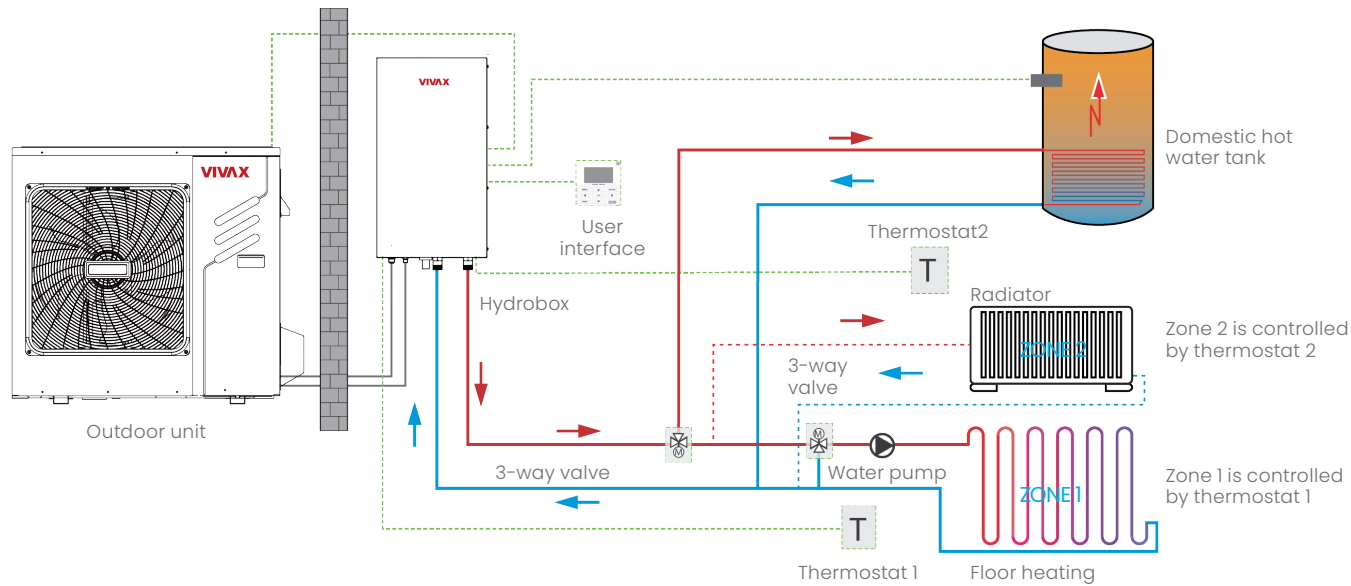

Two zones controlled using only user interface

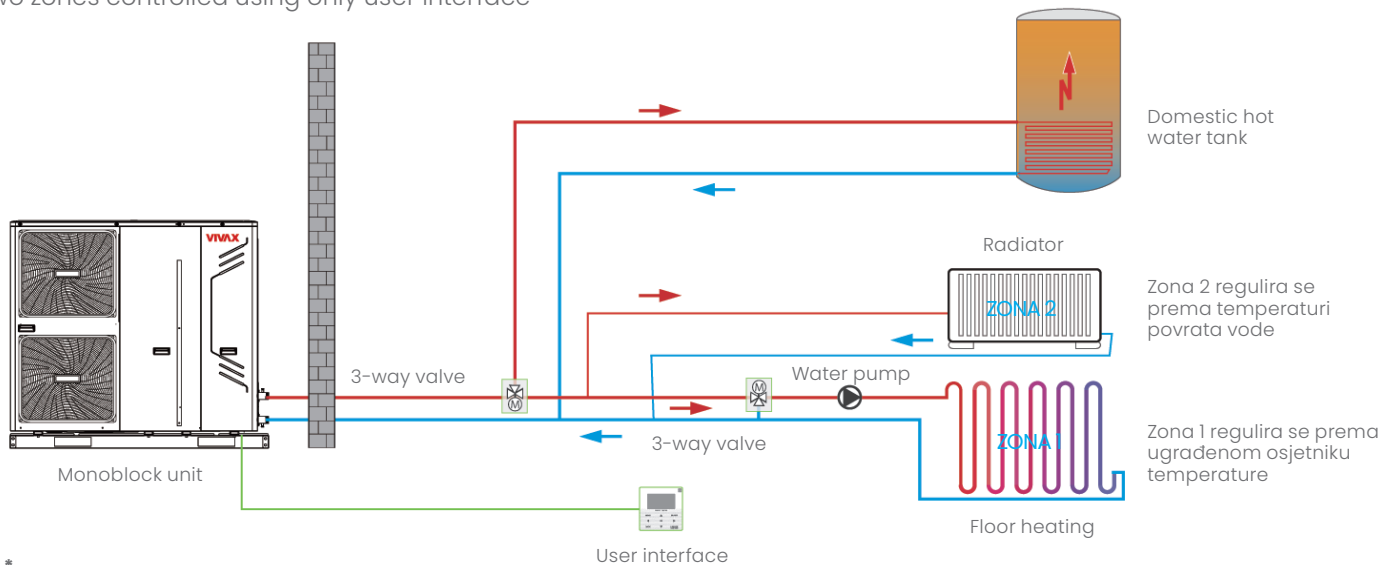

* DHW: Domestic hot water

PRIORITY SETTING FUNCTION AND MULTI MODES CHOICE



Cooling Operation Priority



Space Heating Operation Priority



DHW* Operation Priority



AUTO mode



Disinfect mode¹



Holiday mode



Forced DHW mode



ECO mode



Silent mode

Note:

1. Only when the immersion heater of tank is available can the disinfection mode be used.
2. If the water content in the system is below the minimum, accumulation tank have to be installed.

Complete solution for heating, cooling and domestic hot water | Split system

Application 1

Space Heating Through Floor Heating Loops and Fan Coil Units

The floor heating loops and fan coil units require different operating water temperatures. To achieve these two set points, a mixing station is required. Room thermostats for each zone are optional.

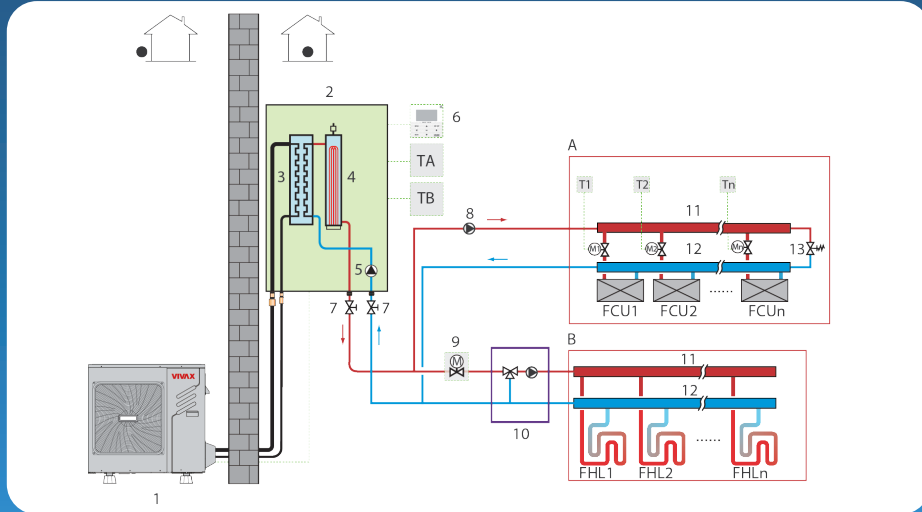

- 1 Outdoor unit
- 2 Hydrobox
- 3 Plate heat exchanger
- 4 Backup electric heater (optional)
- 5 Internal circulator pump
- 6 User interface
- 7 Stop valve (field supplied) *
- 8 External circulator pump (field supplied) *
- 9 Motorized 2-way valve (field supplied) *
- 10 Mixing station (field supplied) *
- 11 Distributor (field supplied) *
- 12 Collector (field supplied) *
- 13 Bypass valve (field supplied) *
- FHL 1...n Floor heating loops (field supplied) *
- FCU 1...n Fan coil units (field supplied) *
- MI...n Motorized valves (field supplied) *
- T1...n Room thermostats (field supplied) *
- TA Zone A thermostat (field supplied) *
- TB Zone B thermostat (field supplied) *

Application 2

Space Heating, Space Cooling and Domestic Hot Water Compatible with Solar Water Heater

Underfloor heating loops and fan coil units are used for space heating and fan coil units are used for space cooling. Domestic hot water is supplied from the domestic hot water tank connected to both the hydronic box and solar water heater. The unit switches to heating or cooling mode according to the temperature detected by the room thermostat. In space cooling mode, the 2-way valve is closed to prevent cold water entering the underfloor heating loops.

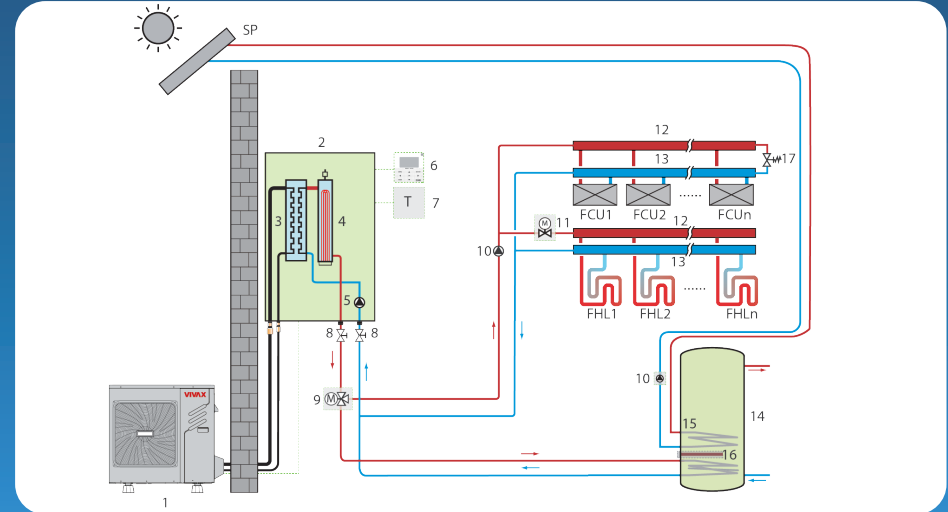

- 1 Outdoor unit
- 2 Hydrobox
- 3 Plate heat exchanger
- 4 Backup electric heater (optional)
- 5 Internal circulator pump
- 6 User interface
- 7 Room thermostat
- 8 Stop valve (field supplied) *
- 9 Motorized 3-way valve (field supplied) *
- 10 External circulator pump (field supplied) *
- 11 Motorized 2-way valve (field supplied) *
- 12 Distributor (field supplied) *
- 13 Collector (field supplied) *
- 14 Domestic hot water tank (field supplied) *
- 15 Heat exchanger coil
- 16 Immersion heater
- 17 Bypass valve (field) *
- FHL 1...n Floor heating loops (field supplied) *
- FCU 1 Fan coil units (field supplied) *
- SP Solar panel

Complete solution for heating, cooling and domestic hot water | Monoblock system

Application 1

Space Heating Only

The room thermostat is used as a switch. When there is a heating request from the room thermostat, the Monoblock unit operates to achieve the target room temperature set on the user interface. When the room temperature reaches the thermostat's set temperature, the unit stops.

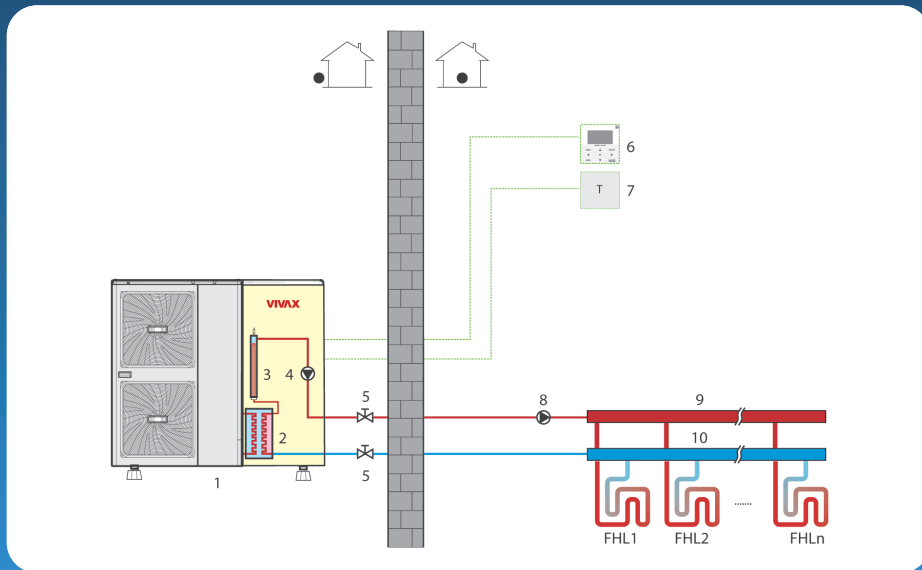

- 1 Heat pump
- 2 Plate heat exchanger
- 3 Backup electric heater(customized)
- 4 Inside circulation pump
- 5 Stop valve (field supplied) *
- 6 User interface
- 7 Room thermostat (field supplied) *
- 8 Outside circulate pump (field supplied) *
- 9 Distributor (field supplied) *
- 10 Collector (field supplied) *
- FHL 1...n Floor heating loops (field supplied) *

Application 2

Space Heating and Domestic Hot Water

The room thermostats are not connected to the Monoblock unit but to a motorized valve. Each room's temperature is regulated by the motorized valve on its water circuit. Domestic hot water is supplied from the domestic hot water tank connected to the Mono unit. A bypass valve is required.

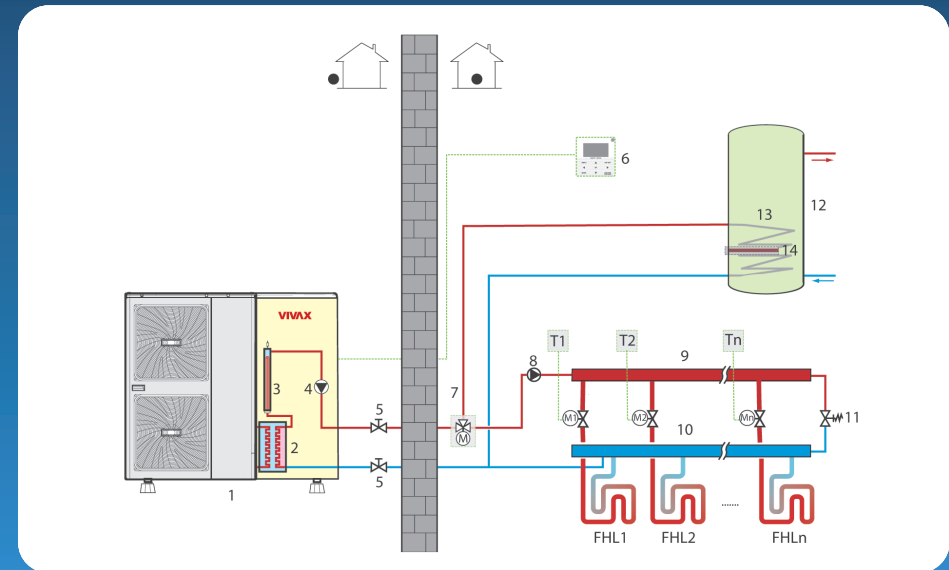

- 1 Heat pump
- 2 Plate heat exchanger
- 3 Backup electric heater(customized)
- 4 Internal circulator pump
- 5 Stop valve *
- 6 User interface
- 7 Motorized 3-way valve *
- 8 External circulator pump *
- 9 Distributor *
- 10 Collector *
- 11 Bypass valve *
- 12 Domestic hot water tank *
- 13 Heat exchanger coil
- 14 Immersion heater
- FHL 1...n Floor heating loops *
- M 1...n Motorized valves *
- T 1...n Room thermostats *

DC Inverter technology | Innovative design

Innovative design ensures lower noise. 2 levels of quiet work mode are available.

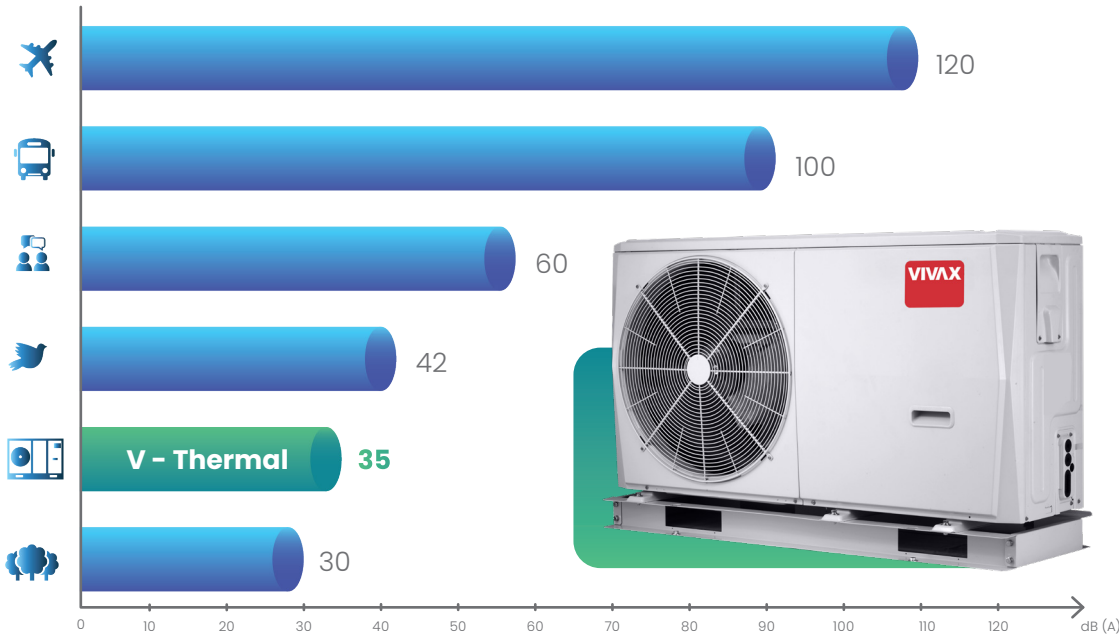

1 | DC inverter motor fan

- CE certification
- Fan motor with continuously variable control
- Silent mode
- Low power consumption

2 | DC Inverter compressor

- CE certification
- Wide operating frequency
- Double rotating compressor
- Spray cooling control
- Compact structure

3 | DC Inverter water pump *

- CE certification
- High degree of efficiency
- Big pump head
- Degree of insulation F
- Level of protection IPX4D

* 18.0 ~ 30.0 kW mono block units - water pump has threespeed options



1 | Suction surface concave design

Reduce the size of wake shedding vortex.
Improve the flow field on blade surface.
Reduce weight and improve efficiency.

2 | Leading edge thickening design

Reduce low frequency noise.
Effectively improve the blade strength.

3 | Trailing edge notch design

Change pressure distribution in the trailing edge of the blade. Reduce the noise of blade.

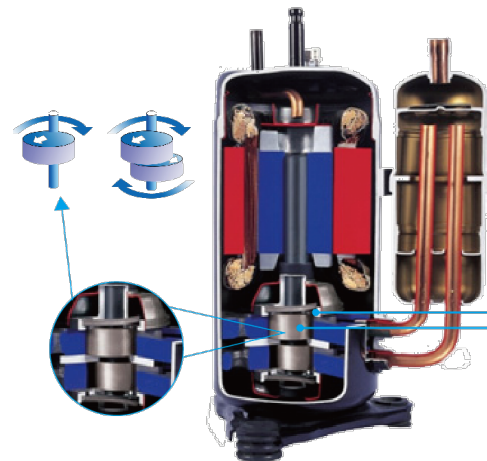
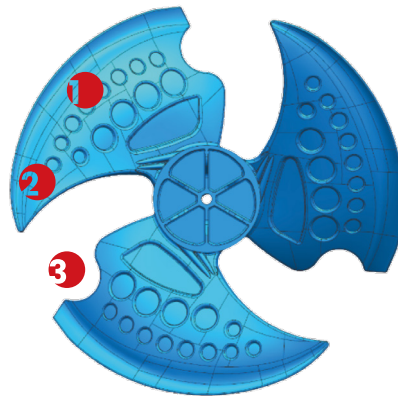

Better balance and extremely low vibration

- 2 balance weights
- Twin eccentric cams

Highly stable moving parts

- Optimize compressor drive technology
- Highly robust bearings
- Compact structure

Pool heat pumps

Complete solution for heating and cooling swimming pool

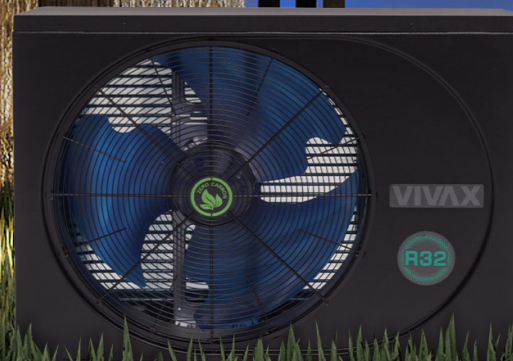

Heating and cooling



Centralized control



APP



Smart grid



Smart memory



Silent mode



System protection

System overview

Smart control

ESG heat pump is compatible with all centralized control pool systems using Modbus protocol and RS485 connector.

App controls and IOT platforms are designed to ensure user ease of operation and reduce equipment maintenance costs.

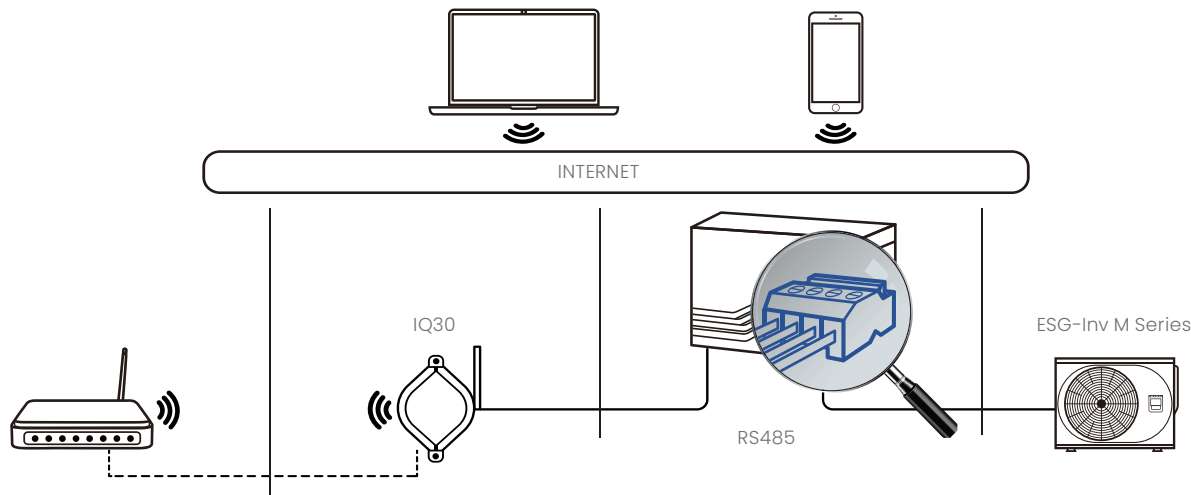

SG - Ready (Smart Grid)

SG-ready ensures that ESG heat pump uses as much clean energy as possible from the smart grid and stores the energy in the swimming pool. When the smart grid is fully supplied with clean energy, ESG heat pumps consume close to zero carbon.

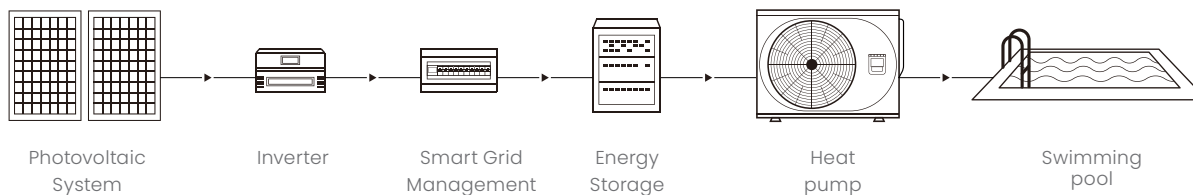

Zero rate CO₂

0 % reduction in heating capacity at temperature conditions from 27 °C to 15 °C

VIVAX heat pump have 0 % heating capacity recession from ambient temp 27 °C to 15 °C, while traditional heat pump have at least 20 % -30 % capacity recession.

Heating & cooling

ESG heat pump contains heating and cooling and automatic modes, covering a wide range of operating environment temperature and target water temperature.

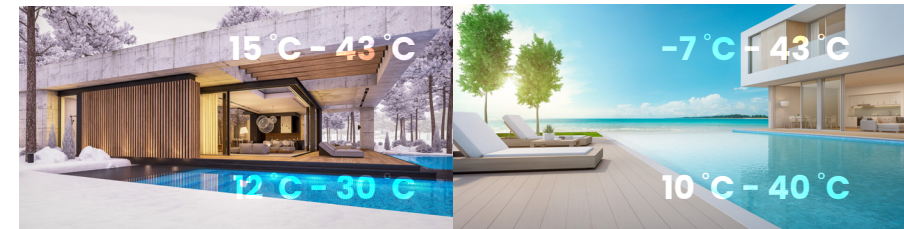

System Protection

ESG series heat pumps have more than 10 protection functions including defrost / pressure / temperature / antifreeze to ensure that the unit runs in a long-term healthy state.

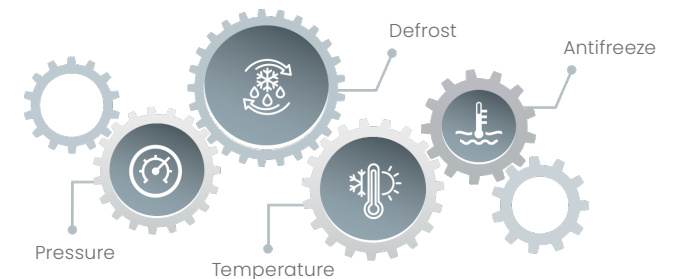

Specifications

Split systems – outdoor unit		HPS-14CH40AERI/O1s R32	HPS-22CH65AERI/O1s R32	HPS-28CH84AERI/O1s R32	HPS-34CHI00AERI/O1s R32
Power supply		220-240 v / 1 Ph / 50 Hz			
Compressor	Type	Twin rotary			
	Motor type	DC motor			
Outdoor fan	Number of fans	1			
	Heat exchanger	Finned tube heat exchanger			
Refrigerant	Type (GWP)	R32 (675)			
	Charged volume (kg)	1,50		1,65	
Sound power level ¹ (dB (A))		56	58	59	60
Unit dimension - W × H × D (mm)		1007 × 712 × 426		1118 × 865 × 523	
Packing dimension - W × H × D (mm)		1065 × 800 × 485		1180 × 890 × 560	
Gross / net weight (kg)		62 / 57		82 / 77	
Piping diameter (mm)	Liquid phase	6,35		9,52	
	Gas phase	15,88			
Connection method		Flared			
Between indoor and outdoor unit (m)	Max. height difference	20			
	Pipe length	2 - 30			
Additional refrigerant	Additional refrigerant charge (g / m)	20		38	
	Max. pipe length for no additional refrigerant (m)	15			
Outdoor air temperature range	Cooling (°C)	-5 ~ 43			
	Heating (°C)	-25 ~ 35			
	DHW (°C)	-25 ~ 43			
Hydrobox model HPS-		42HM65AERI/11s		84HM100AERI/11s	
Heating ¹	Capacity (kW)	4,25	6,2	8,3	10
	Power input (kW)	0,82	1,24	1,6	2
	COP	5,2	5	5,2	5
Heating ²	Capacity (kW)	4,35	6,35	8,2	10
	Power input (kW)	1,14	1,69	2,08	2,63
	COP	3,8	3,75	3,95	3,8
Heating ³	Capacity (kW)	4,4	6	7,5	9,5
	Power input (kW)	1,49	2	2,36	3,06
	COP	2,95	3	3,18	3,1
Cooling ⁴	Capacity (kW)	4,5	6,55	8,4	10
	Power input (kW)	0,81	1,34	1,66	2,08
	EER	5,55	4,9	5,05	4,8
Cooling ⁵	Capacity (kW)	4,7	7	7,4	8,2
	Power input (kW)	1,36	2,33	2,19	2,48
	EER	3,45	3	3,38	3,3
Seasonal space heating energy efficiency class ⁶	Water outlet temperature 35 °C	A+++			
	Water outlet temperature 55 °C	A++			

Note:

¹ Testing standard: EN12102-1.

Abbreviations:

DHW: Domestic hot water

GWP: Global Warming Potential

HPS-41CH120AERI/O3s R32	HPS-48CH140AERI/O3s R32	HPS-53CH155AERI/O3s R32
380-415 V / 3 Ph / 50 Hz		
Twin rotary		
DC motor		
1		
Finned tube heat exchanger		
R32 (675)		
1,84		
64	65	68
1118 × 865 × 523		
1180 × 890 × 560		
116 / 110		
9,52		
15,88		
Flared		
20		
2 - 30		
38		
15		
-5 - 43		
-25 - 35		
-25 - 43		
120HMI55AERI/11s		
12,1	14,5	16
2,44	3,09	3,56
4,95	4,7	4,5
12,3	14,2	16
3,24	3,89	4,44
3,8	3,65	3,6
12	13,8	16
3,87	4,6	5,52
3,1	3	2,9
12	13,5	14,9
3	3,75	4,38
4	3,6	3,4
11,6	12,7	14
4,22	4,98	5,71
4,22	2,55	2,45
A+++		
A++		

Note:

1. Evaporator air in 7 °C, 85 % R.H., Condenser water in / out 30 / 35 °C 2. Evaporator air in 7 °C, 85 % R.H., Condenser water in / out 40 / 45 °C 3. Evaporator air in 7 °C, 85 % R.H., Condenser water in / out 47 / 55 °C 4. Condenser air in 35 °C. Evaporator water in / out 23 / 18 °C 5. Condenser air in 35 °C. Evaporator water in / out 12 / 7 °C 6. Seasonal space heating energy efficiency class testes in average climate general conditions. 7. Relevant EU standards and legislation: EN14511; EN14825; EN50564; EN12102; (EU) No 811/2013; (EU) No 813/2013; OJ 2014/C 207/02:2014.

Split systems – Hydrobox model		HPS-42HM65AERI/11s	HPS-84HM100AERI/11s	HPS-120HM155AERI/11s
Power supply		220-240 V / 1 Ph / 50 Hz		
Sound power level ¹ (dB (A))		38	42	43
Unit dimension - W × H × D (mm)		420 × 790 × 270		
Packing dimension - W × H × D (mm)		525 × 1050 × 360		
Gross / net weight (kg)		43 / 37		45 / 39
Heat exchanger		Plate heat exchanger		
Water pump	Max. pump head (m)	9		
Expansion vessel (Primary circuit)	Volume (L)	8		
	Charge pressure (MPa)	0.1		
Connection	Water side (mm)	R1"		
	Refrigerant - Liquid phase (mm)	6,35	9,52	
	Refrigerant - Gas phase (mm)	15,88	15,88	
Safety valve (MPa)		0,3		
Minimum water flow (m ³ / h)		0,36		0,6
Total water volume (L)		5		
Backup E-heater	Standard mounted (kW)	-		
	Optional (kW)	3 / 9		
	Capacity steps	1 / 3		
	Power supply	3,0 kW	220-240 V / 1 Ph / 50 Hz	
	9,0 kW	380-415 V / 3 Ph / 50 Hz		
Room temperature range (°C)		5 - 35		
Water outlet temperature	Cooling (°C)	5 - 25		
	Heating (°C)	25 - 65		
	DHW (°C)	30 - 60		

Note: 1. Testing standard: EN12102-1.

Split systems – Hydrobox with tank				HPS-42HM65AERI/IT19H3s	HPS-84HM100AERI/IT241H3s	HPS-120HM155AERI/IT241H3s
Power supply				220-240 V / 1 Ph / 50 Hz		
Domestic hot water tank	Type		Stainless steel			
	Material		SUS 316L			
	Water volume (L)		190	240		
	Maximum DHW temperature - Disinfection mode (°C)		70			
	Maximum water pressure (Bar)		10			
	Insulation material		Polyurethane (cyclopentane)			
	Insulation thickness		45			
Sound power level ¹ (dB(A))				38	40	44
Unit dimension - W × H × D (mm)				600 × 1683 × 600	600 × 1943 × 600	
Packing dimension - W × H × D (mm)				730 × 1920 × 730	730 × 2180 × 730	
Gross / net weight (kg)				161 / 140	178 / 157	180 / 159
Heat exchanger				Plate heat exchanger		
Water pump	Max. pump head (m)			9		
Expansion vessel (Primary circuit)	Volume (L)			8		
Connection	Water side (mm)	Heating / Cooling	Outlet	R1"		
			Povrat			
		DHW	Cold inlet	R3/4"		
			Hot outlet			
			Recirculation			
			Refrigerant - Liquid phase (mm)	6,35	9,52	
		Refrigerant - Gas phase (mm)	15,88			
Safety valve (MPa)				0,3		
Minimum water flow (m ³ / h)				0,36		0,6
Total water volume (L)				5		
Backup E-heater	Standard mounted (kW)			3		
	Optional (kW)			0		
	Capacity steps			1		
	Power supply		3,0 kW	220-240 V / 1 Ph / 50 Hz		
Room temperature range (°C)				5 - 35		
Water outlet temperature	Cooling (°C)			5 - 25		
	Heating (°C)			25 - 65		
	DHW (°C)			30 - 60		

Pool heat pumps	HPP-24CH70AERI R32-1	HPP-30CH90AERI R32-1	HPP-41CH120AERI R32-1
Power supply	208 ~ 230 V 1 ~ 50 / 60 Hz		
Recommend pool size (15 °C AT) with pool cover	21	27	36
Recommend pool size (20 °C AT) with pool cover	31,5	40,5	54
Recommend pool size (25 °C AT) with pool cover	52,5	67,5	90
Heat pump type(Swimming pool heat pump)	Inverter		
Material	Metal + plastic		
Operating air temperature (°C)	-7 °C ~ 43 °C		
Boost Mode (Max) capacity - Air 27 °C / Water 26 °C / Humid. 80%	10,3	12,8	14,5
Consumed capacity	1,56	2,13	2,28
COP	6,60	6,00	6,35
Heating capacity - Air 27 °C / Water 26 °C / Humid. 80%	2,9-7,16	2,9-9,15	2,8-12,5
Consumed capacity	0,24-0,95	0,24-1,35	0,23-1,79
COP	12,1-7,5	12,1-6,8	12,2-7,0
Boost Mode (Max) Heating capacity - Air 15 °C / Water 26 °C / Humid. 71 %	7,3	9,3	10,5
Consumed capacity	1,56	2,09	2,28
COP	4,69	4,45	4,60
Heating capacity - Air 15 °C / Water 26 °C / Humid. 71 %	1,9-5,3	1,9-6,8	2,0-9,1
Consumed capacity	0,29-1,04	0,29-1,39	0,29-1,8
COP	6,55-5,1	6,55-4,9	6,9-5,05
Cooling capacity	4,5	5,2	7
Consumed capacity	1,13	1,55	1,75
EER	4	3,35	4
Max current (A)	10,5	11	12
Compressor type	Rotary		
Number of fans	1	1	1
Fan Power Input (W)	50	80	110
Fan Speed (RPM)	450	530	650
Max fan volume (m³/h)	2500	3000	3600
Refrigerant Amount - R32 (kg)	0,55	0,55	0,75
Sound pressure level (1 m) Boost mode	48	52	55
Sound pressure level (3 m) - Boost mode - Theoretical value	39	43	46
Sound pressure level (1 m)	41	43	49
Sound pressure level (3 m) - Theoretical value	32	34	40
Silence mode sound pressure level (1 m)	39	39	40
Silence mode sound pressure level (3 m) - Theoretical value	30	30	31
Water flow (m³/h)	3,1	3,9	5,4
Water pressure drop (kPa)	4,6	7,3	13,8
Water connection (mm)	50	50	50
Gross / net weight (kg)	52 / 46	52 / 46	56 / 50
Unit dimension - W × H × D (mm)	988 × 365 × 712	988 × 365 × 712	988 × 365 × 712
Packing dimension - W × H × D (mm)	1065 × 485 × 845	1065 × 485 × 845	1065 × 485 × 845

Monoblock systems (4 kW - 16 kW) HPM-		14CH40AERis R32-1H3	22CH65AERis R32-1H3	28CH84AERis R32-1H3	34CH100AERis R32-1H9	41CH120AERis R32-3H9	48CH140AERis R32-3H9	53CH155AERis R32-3H9	
Heating A7W35*	Capacity (kW)	4,20	6,35	8,40	10,0	12,1	14,5	15,9	
	Rated power input (kW)	0,82	1,28	1,63	2,02	2,44	3,15	3,53	
	COP	5,10	4,95	5,15	4,95	4,95	4,60	4,50	
Heating A7W45	Capacity (kW)	4,30	6,30	8,10	10,0	12,3	14,1	16,0	
	Rated power input (kW)	1,13	1,70	2,10	2,67	3,32	3,92	4,57	
	COP	3,8	3,70	3,85	3,75	3,70	3,60	3,50	
Heating A7W55	Capacity (kW)	4,40	6,00	7,50	9,50	11,9	13,8	16,0	
	Rated power input (kW)	1,49	2,03	2,36	3,06	3,90	4,68	5,61	
	COP	2,95	2,95	3,18	3,10	3,05	2,95	2,85	
Heating A2W35	Capacity (kW)	4,40	5,50	7,10	8,20	9,2	11,0	13,0	
	Rated power input (kW)	1,10	1,41	1,73	2,05	2,36	3,06	3,77	
	COP	4,00	3,90	4,10	4,00	3,90	3,60	3,45	
Heating A2W45	Capacity (kW)	5,10	5,80	7,40	7,85	10,60	11,50	12,70	
	Rated power input (kW)	1,70	1,93	2,28	2,45	3,53	4,04	4,46	
	COP	3,00	3,00	3,25	3,20	3,00	2,85	2,85	
Heating A2W55	Capacity (kW)	5,10	5,65	7,10	8,10	11,30	12,40	13,30	
	Rated power input (kW)	2,08	2,31	2,73	3,16	4,52	5,06	5,54	
	COP	2,45	2,45	2,60	2,56	2,50	2,45	2,40	
Heating A-7W35	Capacity (kW)	4,7	6,00	7,00	8,00	10,00	12,00	13,10	
	Rated power input (kW)	1,52	2,00	2,19	2,62	3,33	4,21	4,85	
	COP	3,10	3,00	3,20	3,05	3,00	2,85	2,70	
Heating A-7W45	Capacity (kW)	4,30	5,40	6,60	7,35	10,20	11,70	12,80	
	Rated power input (kW)	1,83	2,25	2,59	2,88	4,25	4,98	5,69	
	COP	2,35	2,40	2,55	2,55	2,40	2,35	2,25	
Heating A-7W55	Capacity (kW)	4,00	5,15	6,15	6,85	9,80	11,00	12,50	
	Rated power input (kW)	2,05	2,58	3,00	3,43	4,78	5,37	6,25	
	COP	1,95	2,00	2,05	2,00	2,05	2,05	2,00	
Cooling A35W18	Capacity (kW)	4,50	6,50	8,30	9,90	12,00	13,50	14,90	
	Rated power input (kW)	0,82	1,35	1,64	2,18	3,04	3,75	4,38	
	EER	5,50	4,80	5,05	4,55	3,95	3,60	3,40	
Cooling A35W7	Capacity (kW)	4,70	7,00	7,45	8,20	11,5	12,4	14,0	
	Rated power input (kW)	1,36	2,33	2,22	2,52	4,18	4,96	5,60	
	EER	3,45	3,00	3,35	3,25	2,75	2,50	2,50	
Seasonal space heating energy efficiency class ⁶	Water outlet 35 °C	η _s	191 %	195 %	205 %	204 %	189 %	185 %	182 %
		Class	A+++						
	Water outlet 55 °C	η _s	129 %	138 %	131 %	136 %	135 %	135 %	133 %
		Class	A++						
SCOP	Water outlet temperature 35 °C	4,85	4,95	5,21	5,19	4,81	4,72	4,62	
	Water outlet temperature 55 °C	3,31	3,52	3,36	3,49	3,45	3,47	3,41	
SEER	Water outlet temperature 7 °C	4,99	5,34	5,83	5,98	4,86	4,83	4,67	
	Water outlet temperature 18 °C	7,77	8,21	8,95	8,78	7,04	6,85	6,71	

A: Outdoor temperature
W: Outlet water temperature

Note:
The above data test reference standard
EN14511:2013; EN14825:2013; EN50564:2011; 12102:2011; (EU) No: 811:2013; (EU) No: 813:2013; OJ 2014 / C 207 / 02:2014

Monoblock systems (4 kW - 16 kW) HPM-		14CH40AERis R32-1H3	22CH65AERis R32-1H3	28CH84AERis R32-1H3	34CH100AERis R32-1H9	41CH120AERis R32-3H9	48CH140AERis R32-3H9	53CH155AERis R32-3H9	
Power supply		18	220-240 V / 1 Ph / 50 Hz			380-415 V / 3 Ph / 50 Hz			
MOP (A)		12	18	19	19	14	14	14	
MCA (A)			14	16	17	10	11	12	
Compressor	Type	Double rotary							
	Poles	6							
	Speed range (rps)	10 ~ 120							
	Capacity (60 rps)	5450		7100		14000			
	Input (60 rps)	1735		2230		4380			
	Max. heating frequency (Hz)	78	96	86	96	78	86	92	
	Max. cooling frequency (Hz)	72	84	72	78	70	76	80	
Outdoor fan	Motor type	DC motor							
	Number of fans	1							
	Max fan volume (m³ / h)	2770		4030		4060		4650	
Air side heat exchanger	Number of rows				2		3		
	Number of circuits				8		12		
Refrigerant	Type (GWP)	R32 (675)							
	Charged volume (kg)	1,40				1,75			
Throttle type		Electronic expansion valve							
Sound power level	Heating A7W35 (dB (A))	55	58	59	60	65	65	69	
	Heating maximum (dB (A))	60	61	61	62	65	65	69	
	Heating silence mode ¹ (dB (A))	56	56	57	58	62	62	63	
	Heating pri tihom načinu rada ² (dB (A))	53	53	55	55	56	56	56	
	Cooling A35W18 (dB (A))	56	58	60	60	64	64	69	
	Cooling maximum (dB (A))	60	61	61	62	65	65	69	
	Cooling silence mode ¹ (dB (A))	55	57	57	58	62	62	63	
	Cooling silence mode ² (dB (A))	52	54	54	54	56	56	56	
Unit dimension - W × H × D (mm)		1295 × 792 × 429			1385 × 945 × 526				
Packing dimension - W × H × D (mm)		1375 × 945 × 475			1465 × 1120 × 560				
Gross / net weight (kg)		121 / 89		148 / 121		188 / 160			
Loading quantity - HQ / 40 FT / 20 FT (pcs)		104 / 104 / 50			64 / 64 / 32				
Connection method		Flared							
Outdoor air temperature range	Cooling (°C)	-5 ~ 43							
	Heating (°C)	-25 ~ 35							
	DHW (°C)	-25 ~ 43							
Water side heat exchanger		Pločasti Type							
Water pump	Max. pump head (m)	9							
Expansion vessel (Primary circuit)	Volume (L)	8							
	Charge pressure (Mpa)	0,3							
Water side connection (mm)		R 1"			R 5 / 4"				
Safety valve (MPa)						0,3			
Flow switch (m³ / h)		0,36					0,6		
Total water volume (L)					5				
Backup E-heater	* Optional (kW)	3,0	3,0	3,0	9,0	9,0	9,0	9,0	
	Capacity steps	1							
	Power supply	3,0 kW					220-240 V / 1 Ph / 50 Hz		
		6,0 / 9,0 kW					380-415 V / 3 Ph / 50 Hz		
Water outlet temperature	Cooling (°C)	5 ~ 30							
	Heating (°C)	12 ~ 65							
	DHW - tank (°C)	10 ~ 60							
Nominal return water temperature range	Cooling (°C)	6 ~ 35							
	Heating - DHW (°C)	12 ~ 59							

Monoblock systems (18 kW - 30 kW)			HPM-61CH180AERis R32-3	HPM-75CH220AERis R32-3	HPM-89CH260AERis R32-3	HPM-102CH300AERis R32-3
Heating A7W35*	Capacity (kW)		18000	22000	26000	30100
	Rated power input (kW)		3830	5000	6373	7698
	COP		4,7	4,4	4,08	3,91
Heating A7W45	Capacity (kW)		18000	22000	26000	30000
	Rated power input (kW)		5143	6471	8387	10345
	COP		3,5	3,4	3,1	2,9
Heating A7W55	Capacity (kW)		18000	22000	26000	30000
	Rated power input (kW)		6545	8302	10612	13043
	COP		2,75	2,65	2,45	2,3
Heating A-7W35	Capacity (kW)		18000	21000	22000	23000
	Rated power input (kW)		6667	8077	8800	9388
	COP		2,7	2,6	2,5	2,45
Cooling A35W18	Capacity (kW)		18500	23000	27000	31000
	Rated power input (kW)		3895	5000	6279	7750
	EER		4,75	4,6	4,3	4
Cooling A35W7	Capacity (kW)		17000	21000	26000	29500
	Rated power input (kW)		5574	7119	9630	11569
	EER		3,05	2,95	2,7	2,55
Seasonal space heating energy efficiency class	Water outlet temperature 35 °C	Class	A+++			
	Water outlet temperature 55 °C	Class	A++			
SCOP	Water outlet temperature 35 °C		4,6	4,53	4,5	4,2
	Water outlet temperature 55 °C		3,2	3,23	3,15	3,15
SEER	Water outlet temperature 7 °C		4,7	4,7	4,66	4,49
	Water outlet temperature 18 °C		5,48	5,67	5,88	5,71

Monoblock systems (18 kW – 30 kW)		HPM-61CH180AERis R32-3	HPM-75CH220AERis R32-3	HPM-89CH260AERis R32-3	HPM-102CH300AERis R32-3
Power supply		380-415 V / 3 Ph / 50 Hz			
MOP (A)		18	21	24	28
MCA (A)		21	24,5	27	28,5
Compressor		Twin rotary			
Outdoor fan	Motor type	DC fan			
	Number of fans	2			
Air side heat exchanger		Plate type			
Water pump	Max. pump head (m)	12			
Refrigerant	Type (GWP)	R32			
	Charged volume (kg)	5			
Throttle type		Electronic expansion valve			
Sound power level ² (dB)		71	73	75	77
Water flow (m ³ / h)		3,1	3,78	4,47	5,18
Internal water volume (L)		3,5	3,5	3,5	3,5
Unit dimension - W × H × D (mm)		1129 x 1558 x 440			
Packing dimension - W × H × D (mm)		1220 x 1735 x 565			
Gross / net weight (kg)		206 / 177			
Water side connections (inch)		1-1/4" BSP	1-1/4" BSP	1-1/4" BSP	1-1/4" BSP
Water outlet temperature	Cooling (°C)	-5 ~ 46			
	Heating (°C)	-25 ~ 35			
	DHW - tank (°C)	-25 ~ 43			
Water inlet temperature	Cooling (°C)	5 ~ 25			
	Heating - DHW (°C)	25 ~ 60			

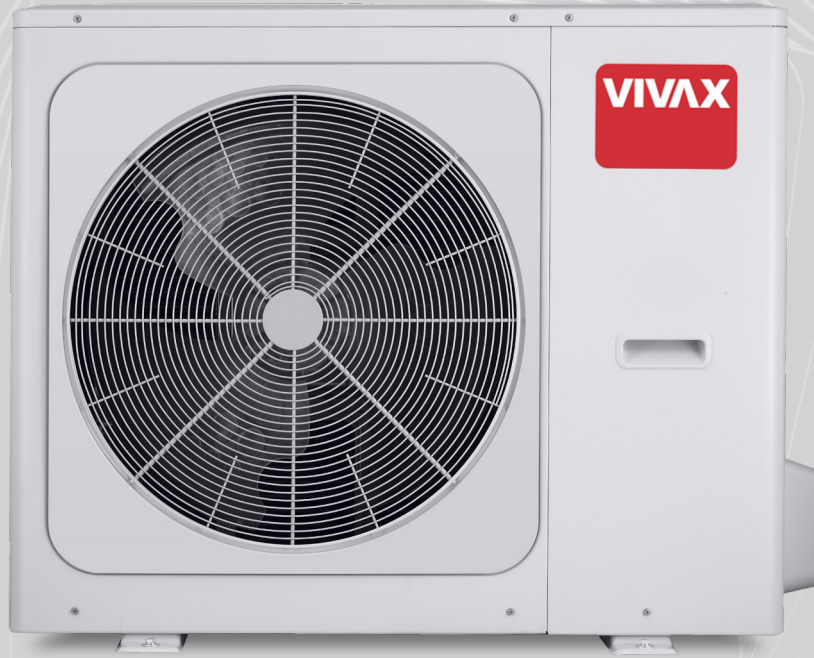

VIVAX
Simply good.



VIVAX PARTNER